

## Universal PROTRXion™ Mounting Bracket



# PROTRXion™ Accessories User Manual



## Applicable Models

Model	Part Number
Universal PROTRXion™ Mounting Bracket	03-59293-001

Release Date	Revision	Scope of Change
2022-11-17	V1.2	Minor changes to V1 release

## Document Information

Inventus Power® and PROTRXion™ are trademarks of Inventus Power.

Copyright© 2022 Inventus Power All rights reserved.

## Technical Support

If you have any technical questions regarding the PROTRXion™ accessory, please contact our technical support team at:

**Phone: +1.877.423.4242**

**E-mail: [tech\\_support@inventuspower.com](mailto:tech_support@inventuspower.com)**

# Contents



- Tools Required** ..... 4
- What's in the box?** ..... 4
- Single Battery Width-Mount Bracket Assembly** ..... 5-9
- Single Battery Height-Mount Bracket Assembly** ..... 10-14
- Single Battery Length-Mount Bracket Assembly** ..... 15-19
- Two Battery Width-Mount Bracket Assembly** ..... 20-24

## Tools Required



**Prior to installation, place the battery in Ship Mode by holding down the power button for 20 seconds. The following equipment is required for installing the Universal PROTRXion™ Mounting Bracket:**

- Safety glasses or other eye protection
- 4mm (5/32") Hex Allen Wrench
- 10mm (3/8") Wrench
- 10mm drill bit
- Hand-held drill

## What's in the box?

### Parts List:

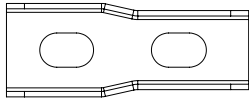

C: Metal Bracket (1X)

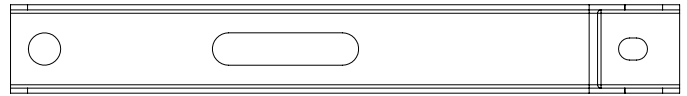

A: Metal Bracket (1X)



B: Metal Bracket (1X)



D:  
M6 Washer (4X)



E:  
M6x1x12mm  
Flat Head Bolt (2X)



F:  
Rubber Cap (2X)



G:  
M6 Split Lock Washer (4X)



H:  
M6 Anti-Loosening Nut (4X)



J:  
M6 Battery Hold-Down  
Bolts (2X)

## Single Battery Width-Mount Bracket Assembly

### Parts List:

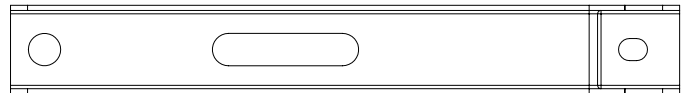

A: Metal Bracket (1X)



B: Metal Bracket (1X)



D:  
M6 Washer (3X)



E:  
M6x12mm  
Flat Head Bolt (1X)



F:  
Rubber Cap (2X)



G:  
M6 Split Lock Washer (3X)



H:  
M6 Anti-Loosening Nut (3X)



J:  
M6 Battery Hold-Down  
Bolts (2X)

### Step 1: Place Metal Bracket A inside Metal Bracket B

Brackets should overlap to align the left-most hole on Metal Bracket B with the right-most edge of the slot on Metal Bracket A.

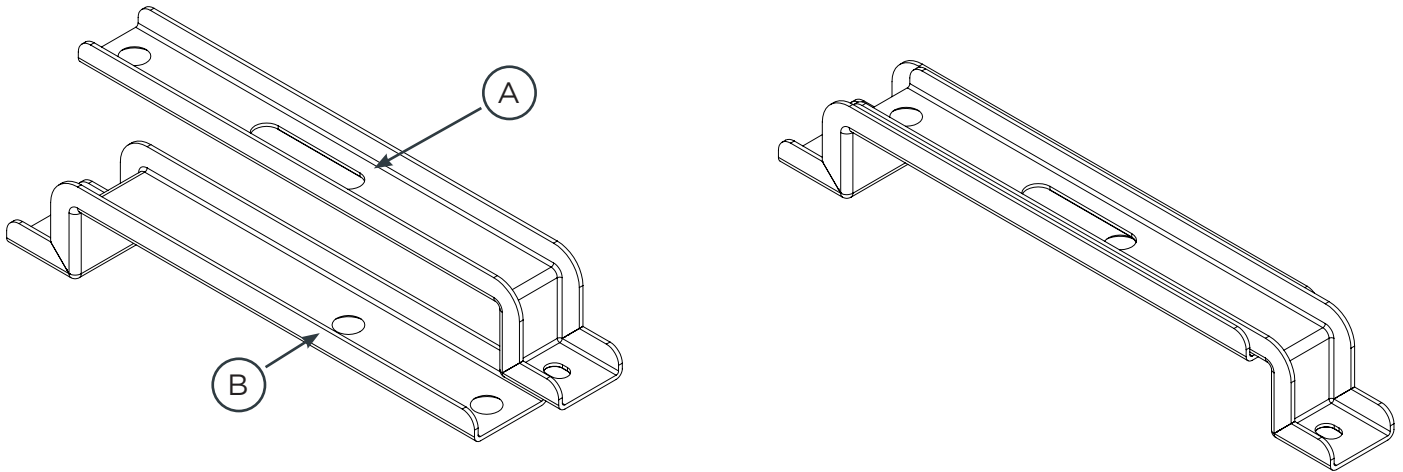

### Step 2: Assemble the two metal brackets together

Use the Allen wrench tool to hold the bolt from spinning while tightening the nut with the 10mm wrench. Tighten the nut to a recommended torque of  $8.5 \pm 0.5$  Nm.

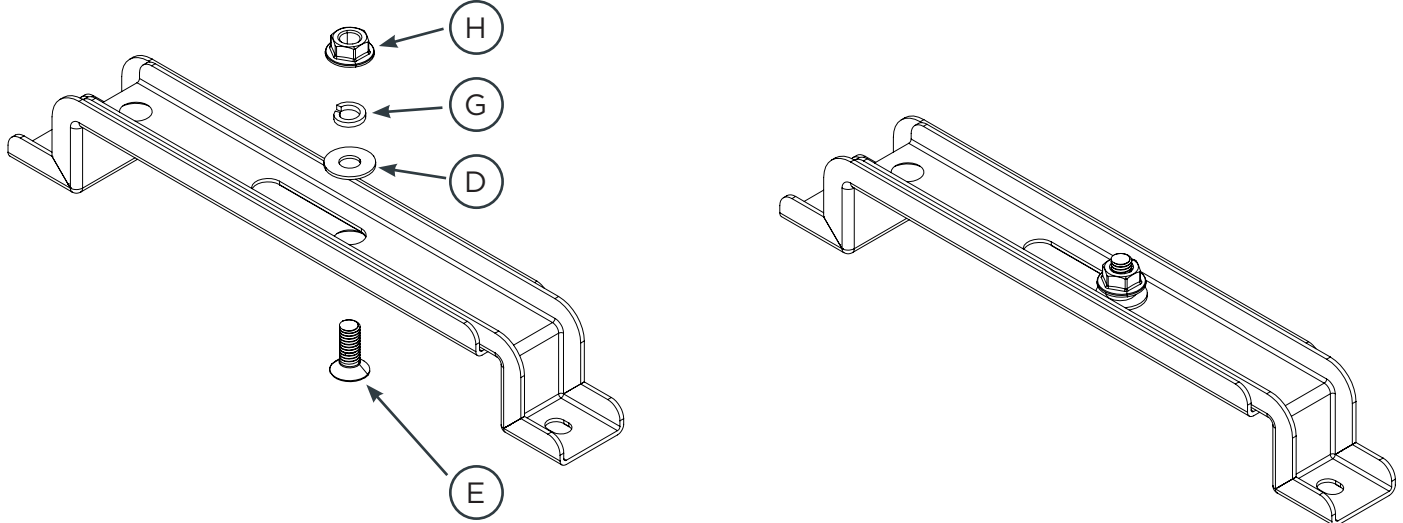

**Note:** This is the assembly orientation recommended for golf fleet carts such as Club Car Precident, EZ-GO TXT, EZ-GO RXV, and Yamaha Drive. For vehicle specific mounting instructions please go to [www.inventuspower.com/markets/golf/](http://www.inventuspower.com/markets/golf/).

### Step 3: Drill holes for J-hook battery hold down bolts

Drill 10mm diameter holes in the battery tray 19.5 cm apart from each other. It is recommended to align the bracket such that it does not cover the terminals, communication ports, LEDs, or push button on the battery.

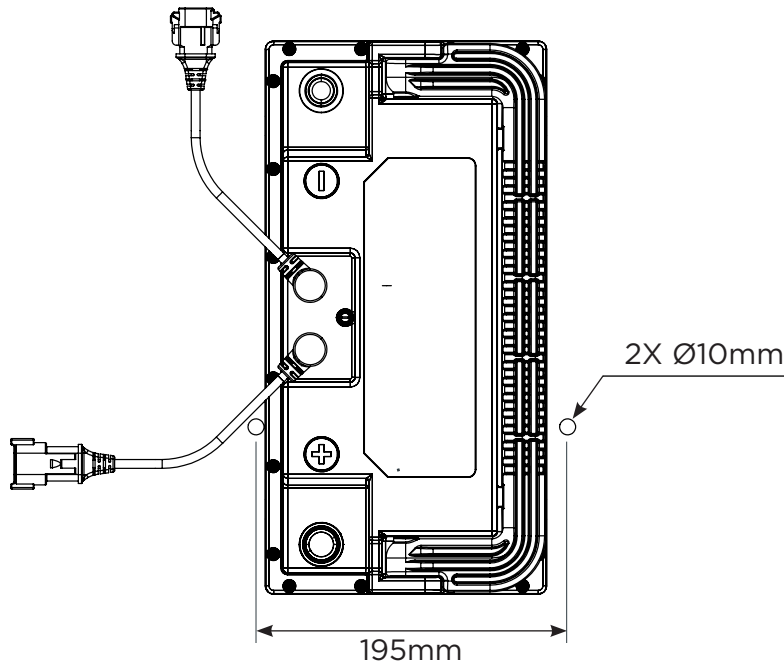

### Step 4: Feed battery hold-down bolt through right-side hole

Angle the J-hook end of the Battery Hold-Down Bolt (J) and feed it through the right-side hole. Rotate the bolt so that it is vertical. **DO NOT let go of the bolt** as the bolt will drop below the vehicle.

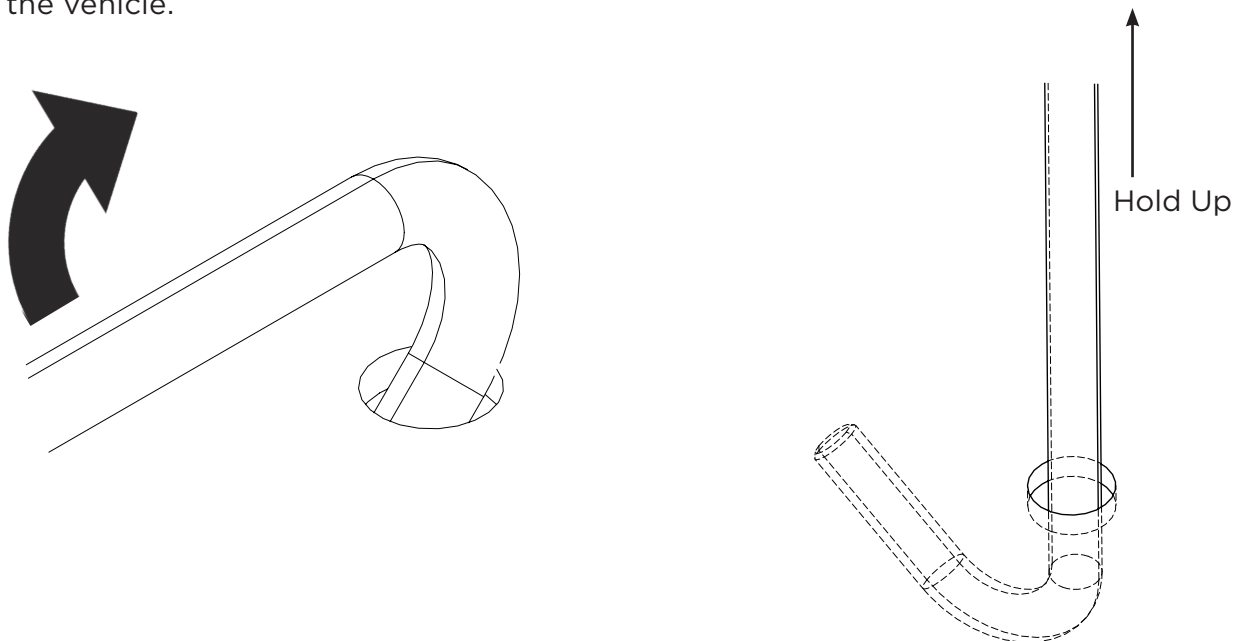

**Step 5: Loosly apply washers and nut to right-side Battery Hold-Down Bolt (J)**

Place the bracket aligned with the holes and feed the Battery Hold-Down Bolt through the right-side hole on the assembled bracket. Apply the Washer (D), then the Split Lock Washer (G), then the Anti-Loosening Nut (H) to the Battery Hold-Down Bolt (J) to loosely hold the right-side Battery Hold-Down Bolt in place.

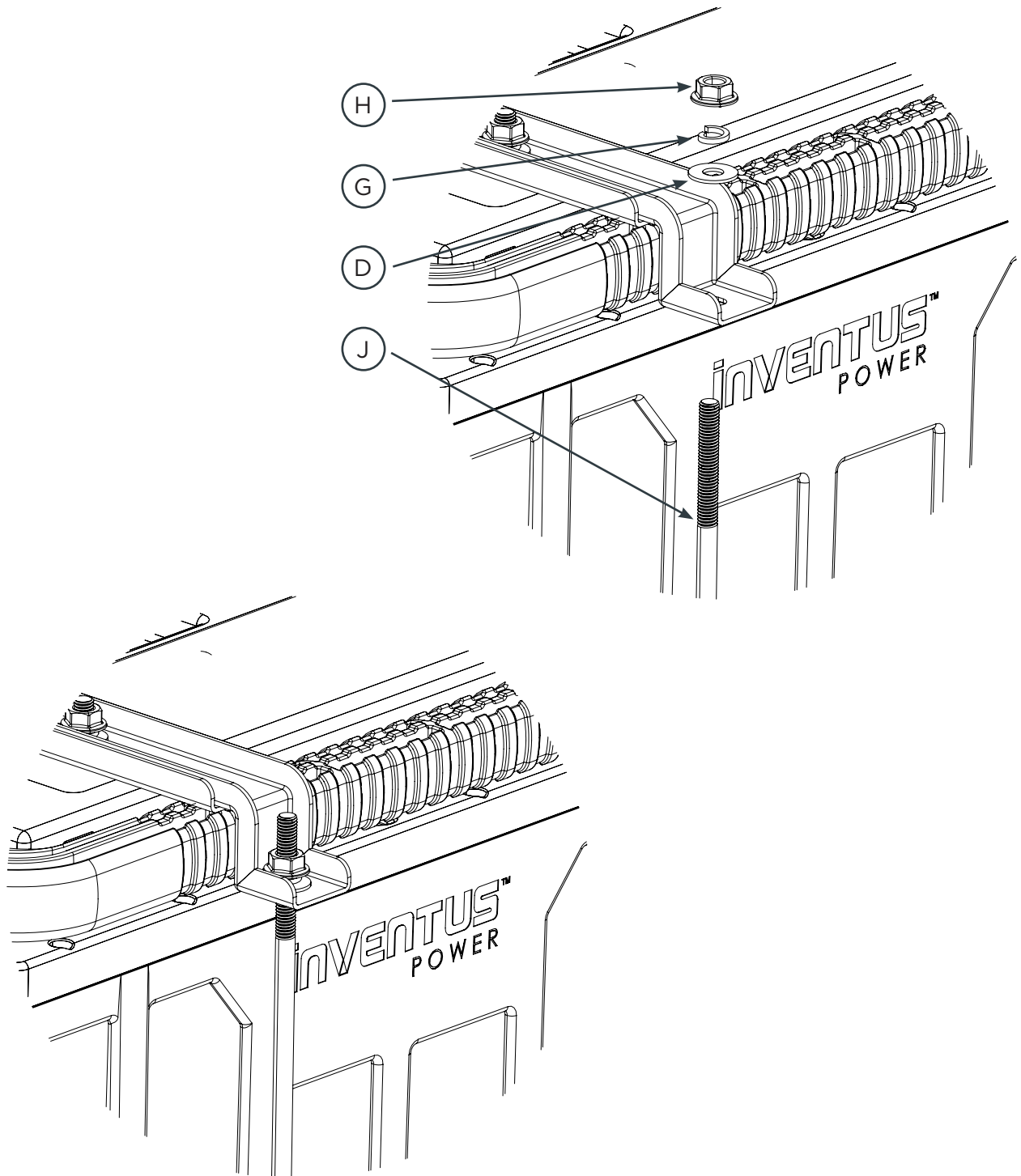



**Step 6: Repeat steps 4 and 5 on the left side to place the left-side Battery Hold-Down Bolt (J)**

**Step 7: Tighten both Anti-Loosening Nuts (H) to a recommended torque of  $8.5 \pm 0.5$  Nm**

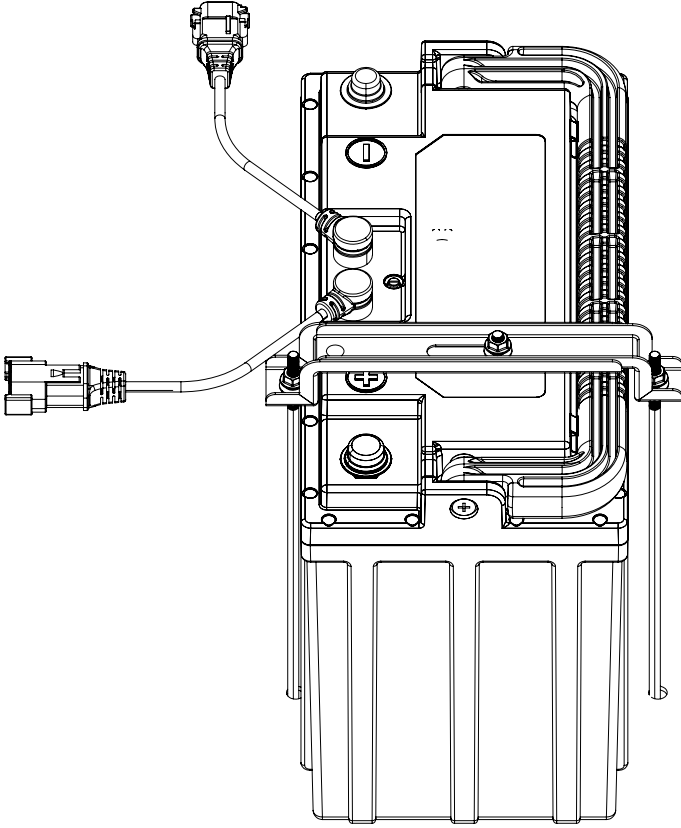

**Step 8: Apply Rubber Caps (F) to the top of each Battery Hold-Down Bolt (J)**

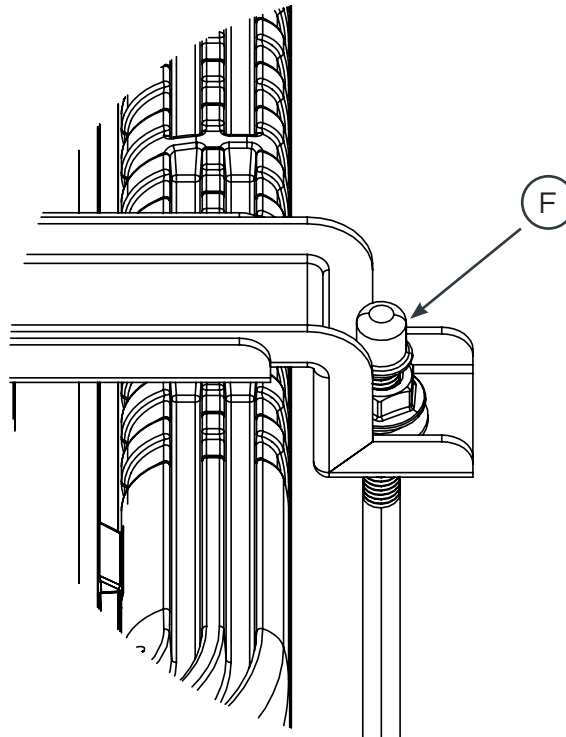

## Single Battery Height-Mount Bracket Assembly

### Parts List:

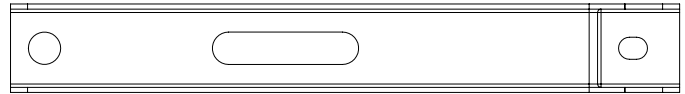
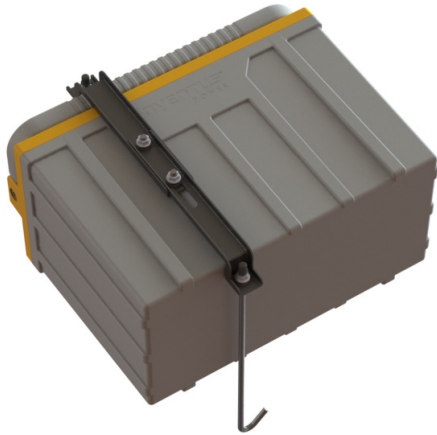

A: Metal Bracket (1X)

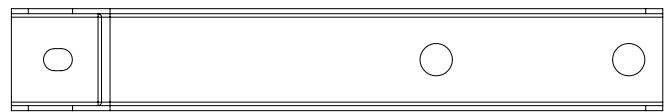

B: Metal Bracket (1X)



D:  
M6 Washer (4X)



E:  
M6x12mm  
Flat Head Bolt (2X)



F:  
Rubber Cap (2X)



G:  
M6 Split Lock Washer (4X)



H:  
M6 Anti-Loosening Nut (4X)



J:  
M6 Battery Hold-Down  
Bolts (2X)

**Step 1: Place Metal Bracket A inside Metal Bracket B**

Brackets should overlap to align the left-most hole on Metal Bracket B with the left-most hole on Metal Bracket A.

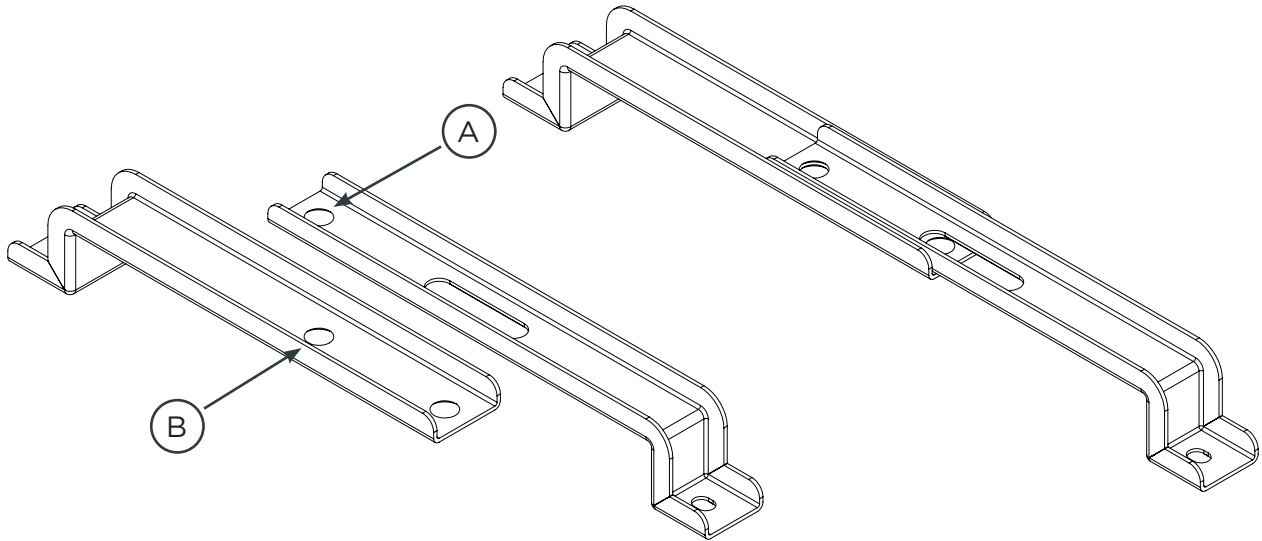

**Step 2: Assemble the two metal brackets together**

Use the Allen wrench tool to hold the bolts from spinning while tightening the nuts with the 10mm wrench. Tighten the nuts to a recommended torque of  $8.5 \pm 0.5$  Nm.

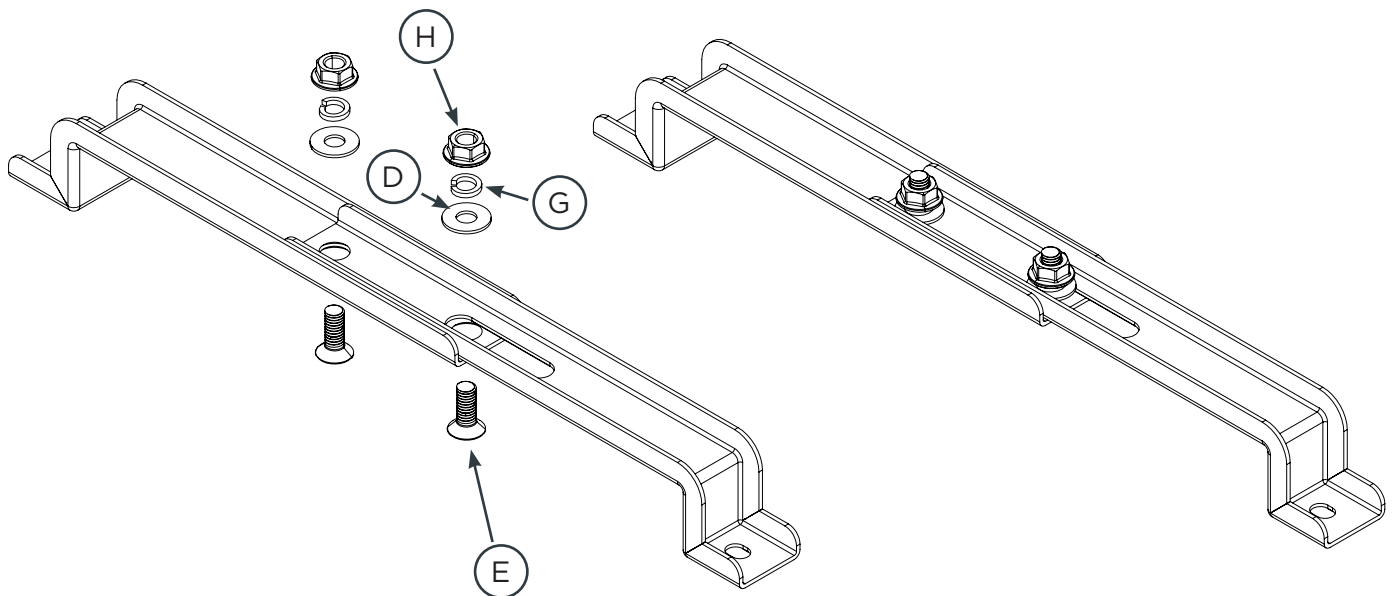

**Step 3: Drill holes for J-hook battery hold down bolts**

Drill 10mm diameter holes in the battery tray 28.2 cm apart from each other. It is recommended to align the bracket such that it does not cover the terminals, communication ports, LEDs, or push button on the battery.

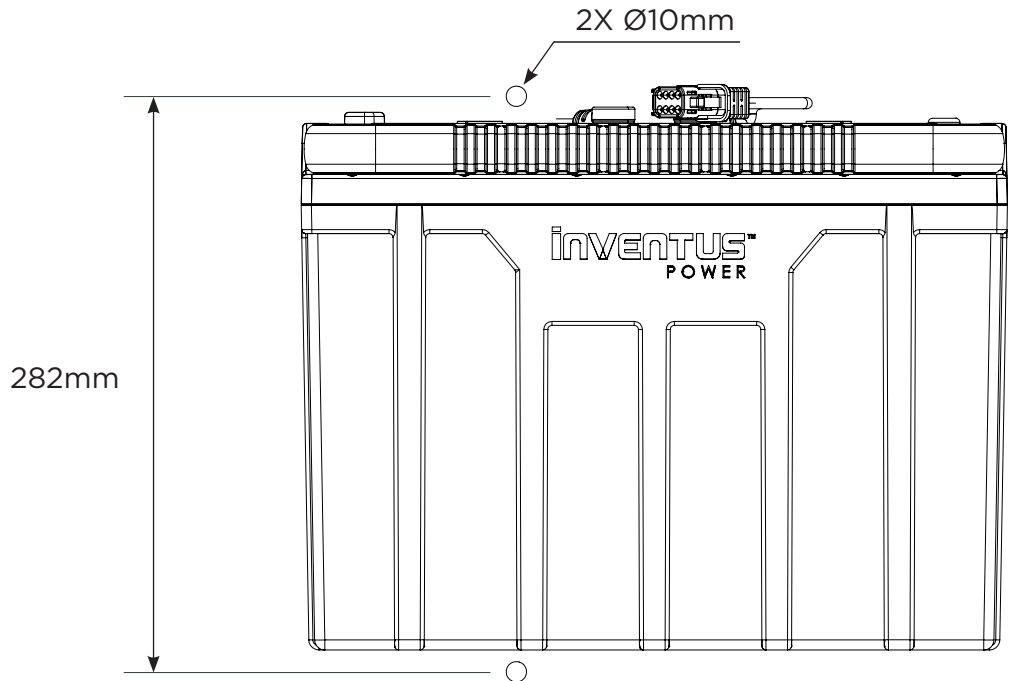

**Step 4: Feed battery hold-down bolt through right-side hole**

Angle the J-hook end of the Battery Hold-Down Bolt (J) and feed it through the right-side hole. Rotate the bolt so that it is vertical. Do not let go of the bolt as the bolt will drop below the vehicle.

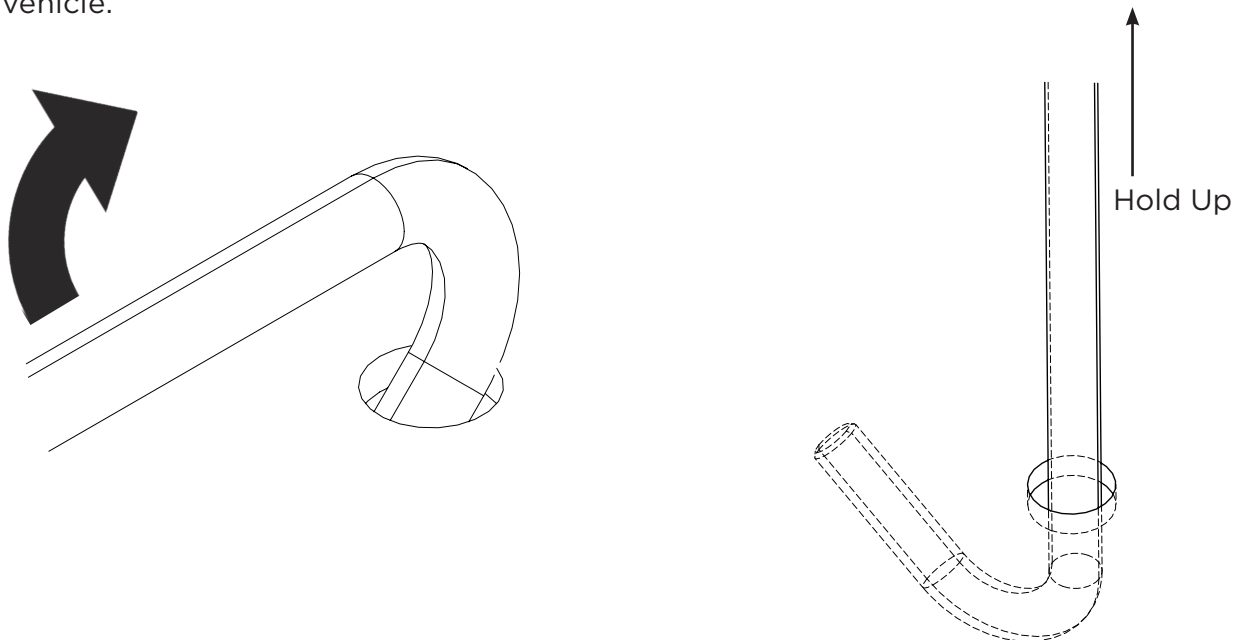

**Step 5: Loosly apply washers and nut to right-side Battery Hold-Down Bolt (J)**

Place the bracket aligned with the holes and feed the Battery Hold-Down Bolt through the right-side hole on the assembled bracket. Apply the Washer (D), then the Split Lock Washer (G), then the Anti-Loosening Nut (H) to the Battery Hold-Down Bolt (J) to loosely hold the right-side Battery Hold-Down Bolt in place.

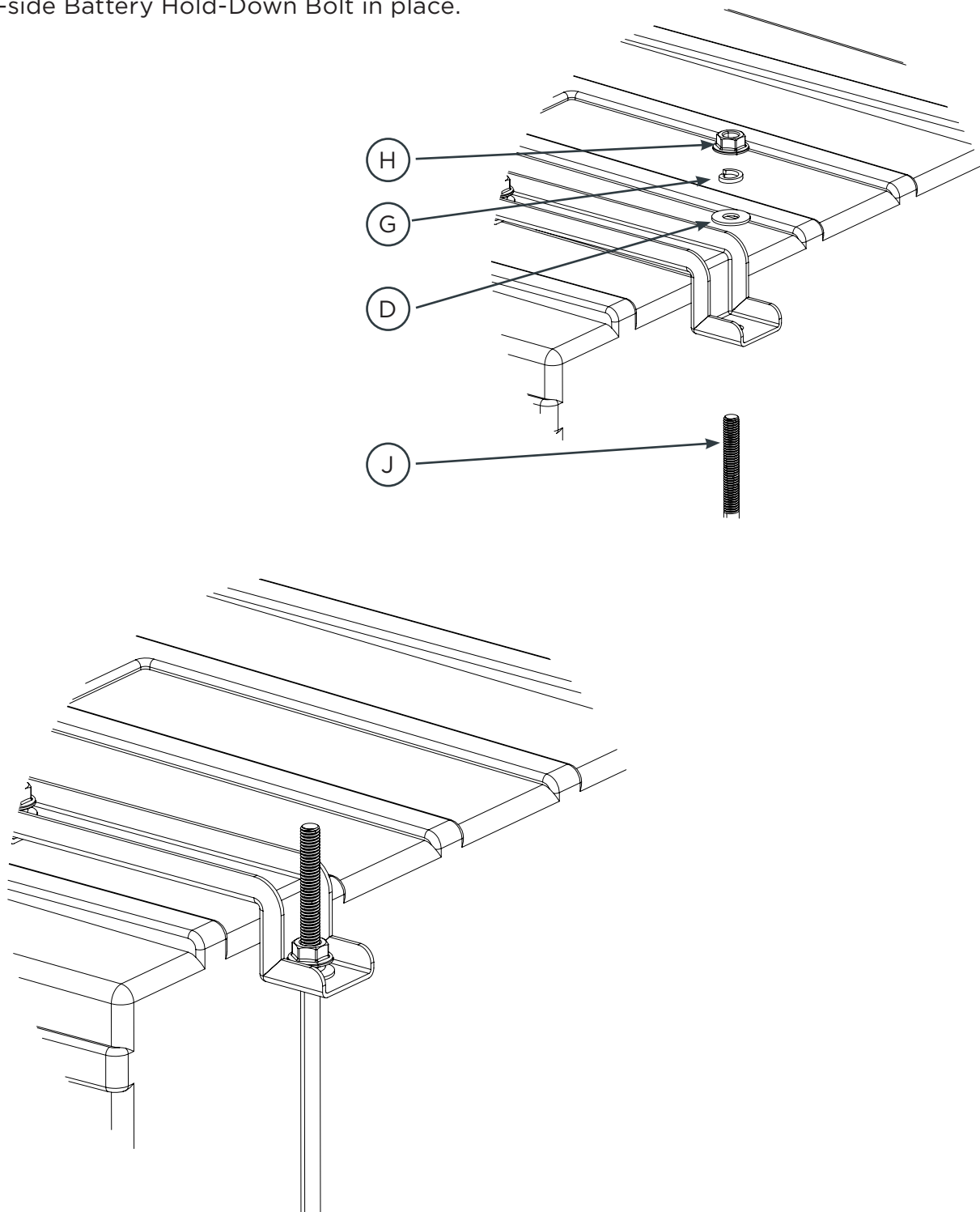

**Step 6: Repeat steps 4 and 5 on the left side to place the left-side Battery Hold-Down Bolt (J)**



**Step 7: Tighten both Anti-Loosening Nuts (H) to a recommended torque of  $8.5 \pm 0.5$  Nm**

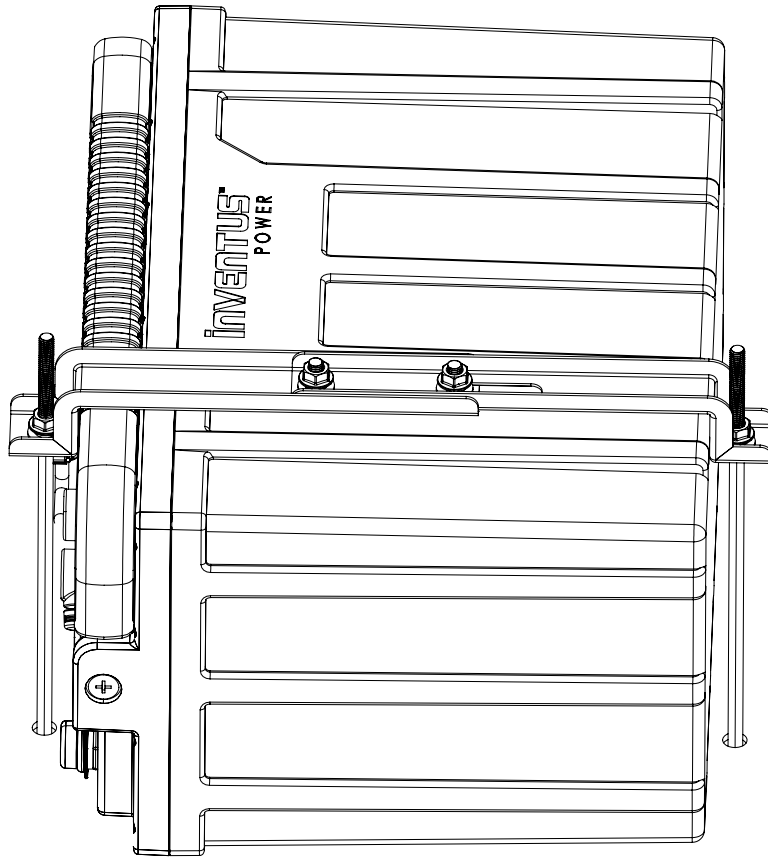

**Step 8: Apply Rubber Caps (F) to the top of each Battery Hold-Down Bolt (J)**

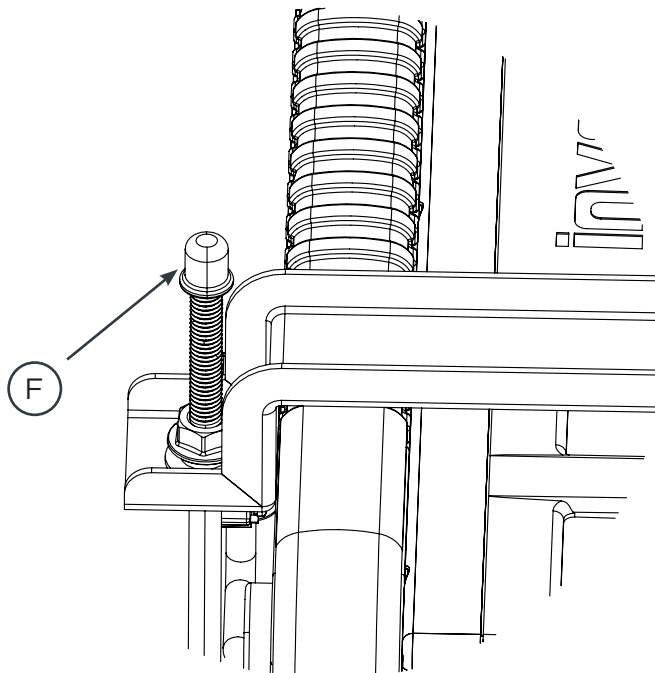

## Single Battery Length-Mount Bracket Assembly

### Parts List:

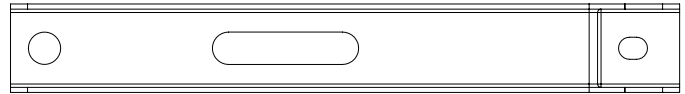

A: Metal Bracket (1X)

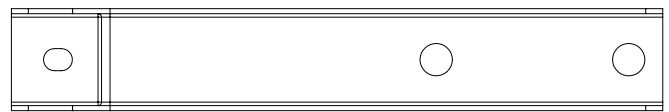

B: Metal Bracket (1X)



D:  
M6 Washer (4X)



E:  
M6x12mm  
Flat Head Bolt (2X)



F:  
Rubber Cap (2X)



G:  
M6 Split Lock Washer (4X)



H:  
M6 Anti-Loosening Nut (4X)



J:  
M6 Battery Hold-Down  
Bolts (2X)

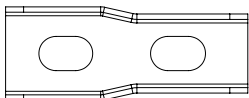

C: Metal Bracket (1X)

### Step 1: Place Metal Bracket C inside Metal Brackets A and B

Brackets should overlap to align the left-most slot on Metal Bracket C with the right-most hole on Metal Bracket B and align the right-most slot on Metal Bracket C with the left-most hole on Metal Bracket A.

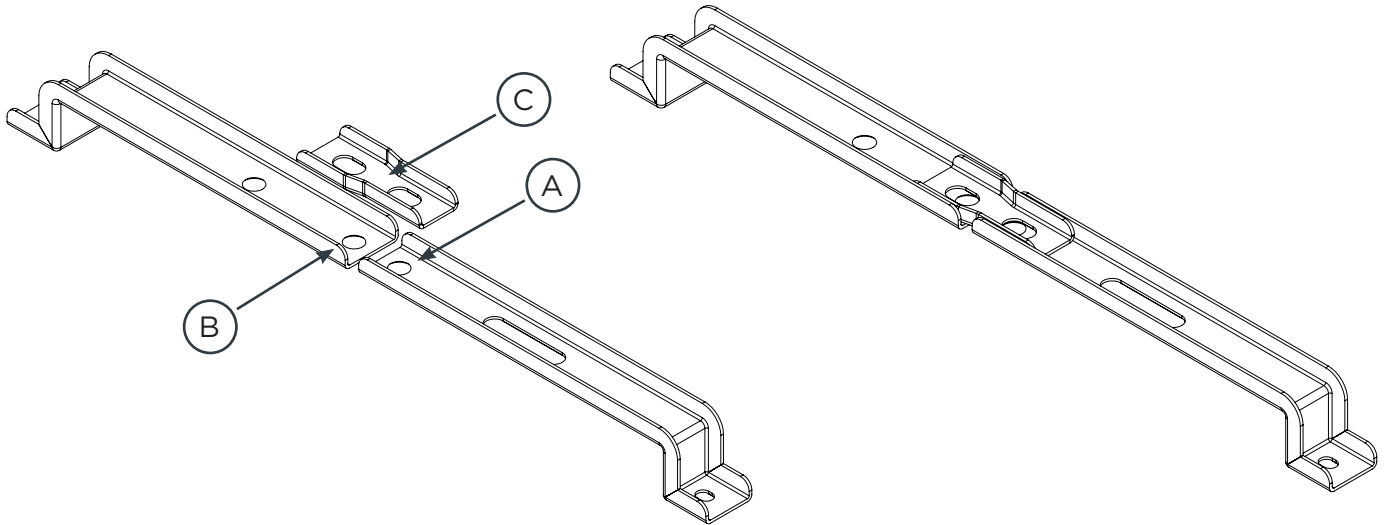

### Step 2: Assemble the two metal brackets together

Use the Allen wrench tool to hold the bolts from spinning while tightening the nuts with the 10mm wrench. Tighten the nuts to a recommended torque of  $8.5 \pm 0.5$  Nm. Note that the slots on Metal Bracket C are adjustable to align the bracket to fit the length of the battery tight.

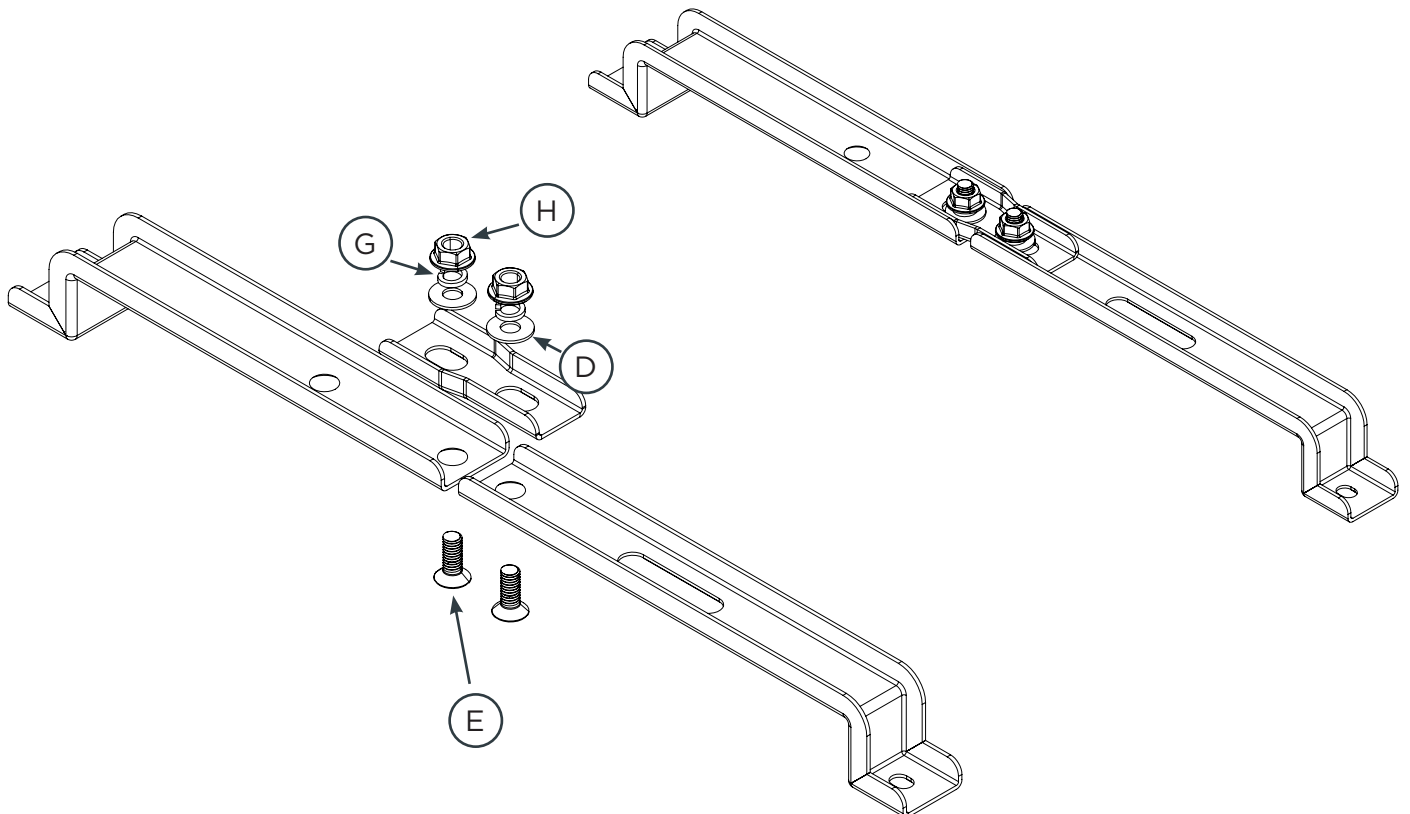



**Step 3: Drill holes for J-hook battery hold down bolts**

Drill 10mm diameter holes in the battery tray 36.9 cm apart from each other. It is recommended to align the bracket such that it does not cover the terminals, communication ports, LEDs, or push button on the battery.

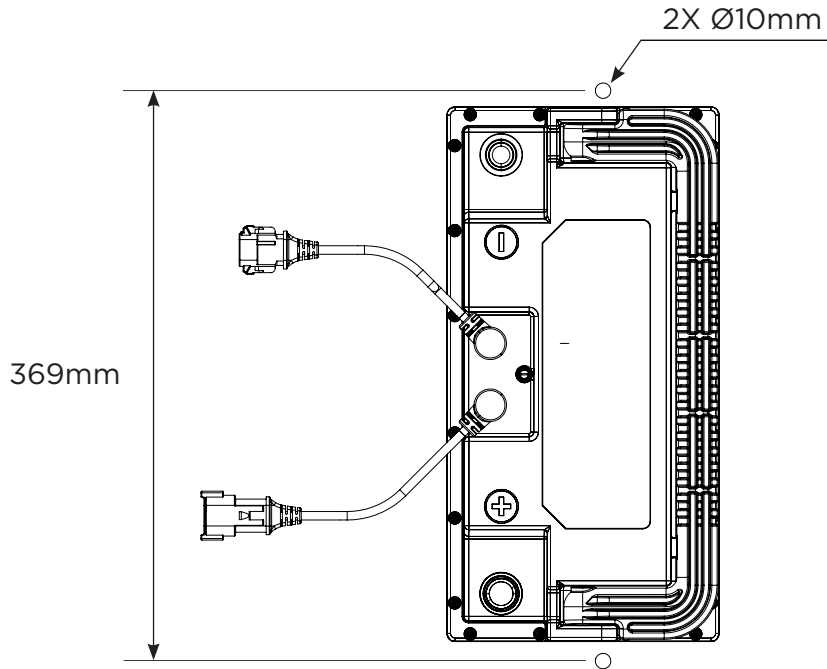

**Step 4: Feed battery hold-down bolt through right-side hole**

Angle the J-hook end of the Battery Hold-Down Bolt (J) and feed it through the right-side hole. Rotate the bolt so that it is vertical. Do not let go of the bolt as the bolt will drop below the vehicle.

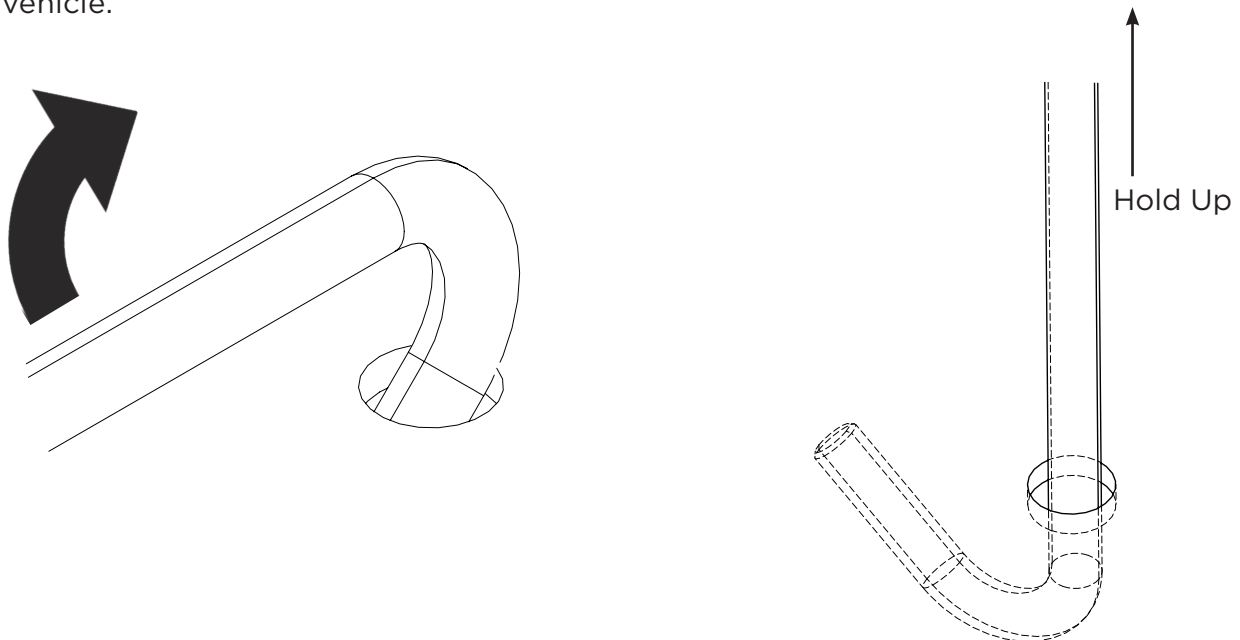

**Step 5: Loosly apply washers and nut to right-side Battery Hold-Down Bolt (J)**

Place the bracket aligned with the holes and feed the Battery Hold-Down Bolt through the right-side hole on the assembled bracket. Apply the Washer (D), then the Split Lock Washer (G), then the Anti-Loosening Nut (H) to the Battery Hold-Down Bolt (J) to loosely hold the right-side Battery Hold-Down Bolt in place.

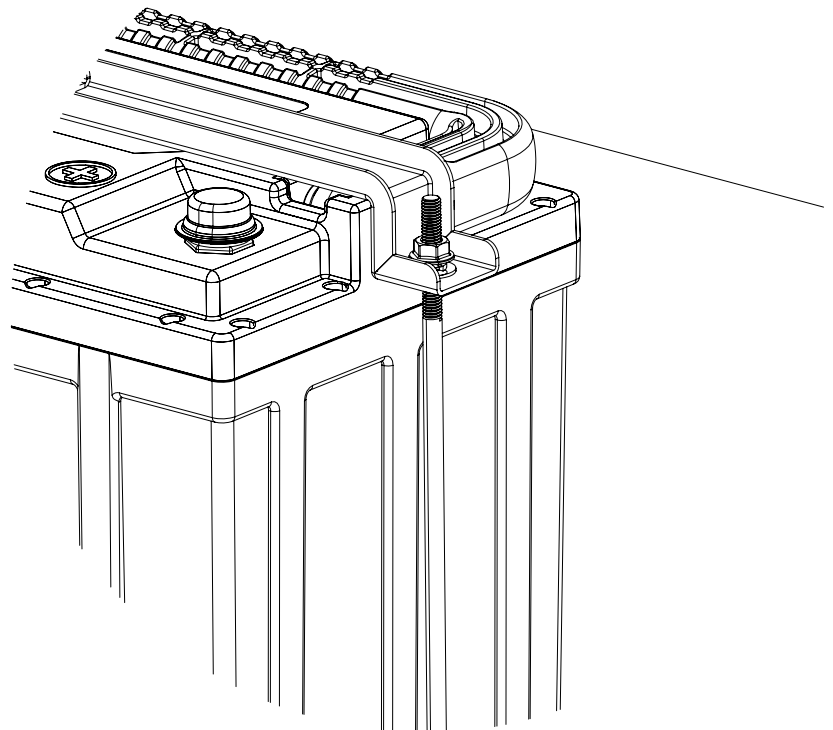
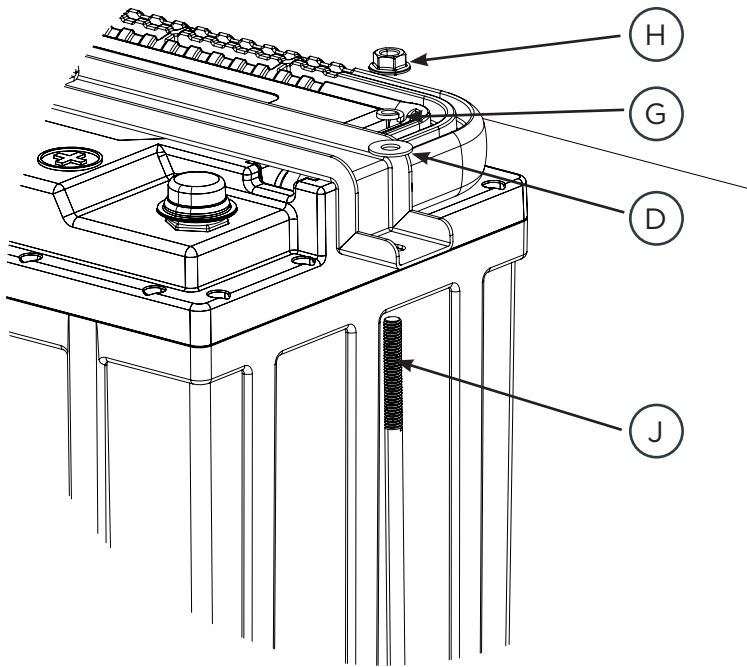

**Step 6: Repeat steps 4 and 5 on the left side to place the left-side Battery Hold-Down Bolt (J)**



**Step 7: Tighten both Anti-Loosening Nuts (H) to a recommended torque of  $8.5 \pm 0.5$  Nm**

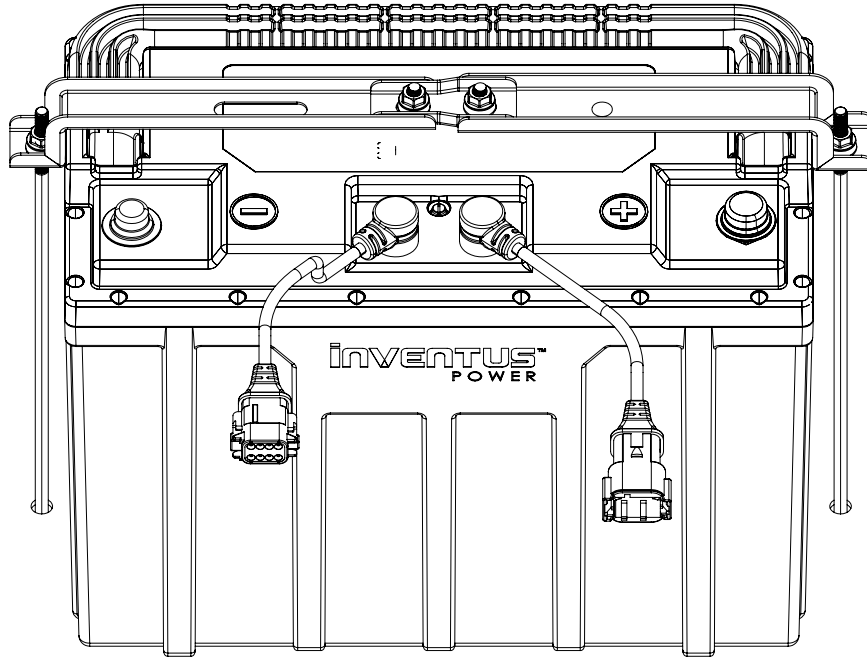

**Step 8: Apply Rubber Caps (F) to the top of each Battery Hold-Down Bolt (J)**

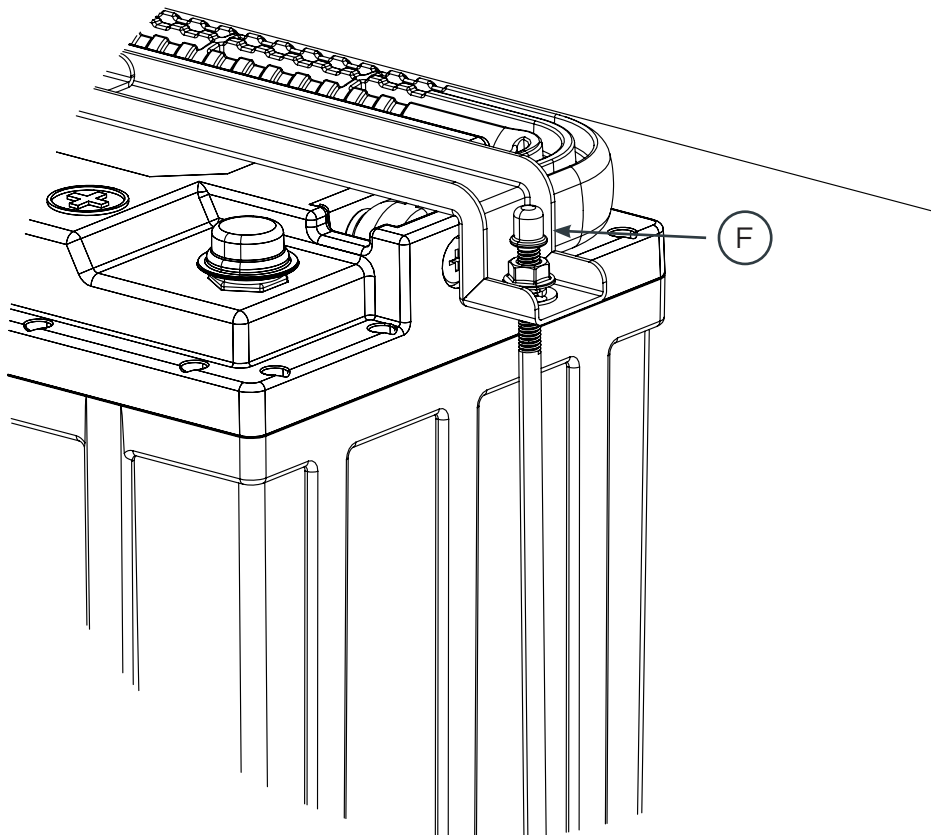

## Two Battery Width-Mount Bracket Assembly

### Parts List:

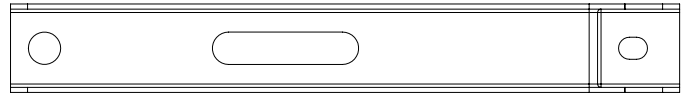

A: Metal Bracket (1X)

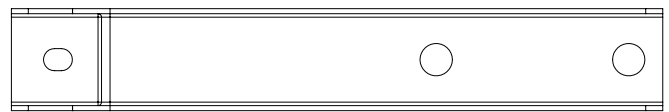

B: Metal Bracket (1X)



D:  
M6 Washer (4X)



E:  
M6x12mm  
Flat Head Bolt (2X)



F:  
Rubber Cap (2X)



G:  
M6 Split Lock Washer (4X)



H:  
M6 Anti-Loosening Nut (4X)



J:  
M6 Battery Hold-Down  
Bolts (2X)

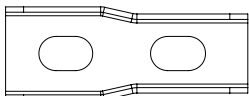

C: Metal Bracket (1X)

### Step 1: Place Metal Bracket C inside Metal Brackets A and B

Brackets should overlap to align the left-most slot on Metal Bracket C with the right-most hole on Metal Bracket B and align the right-most slot on Metal Bracket C with the left-most hole on Metal Bracket A.

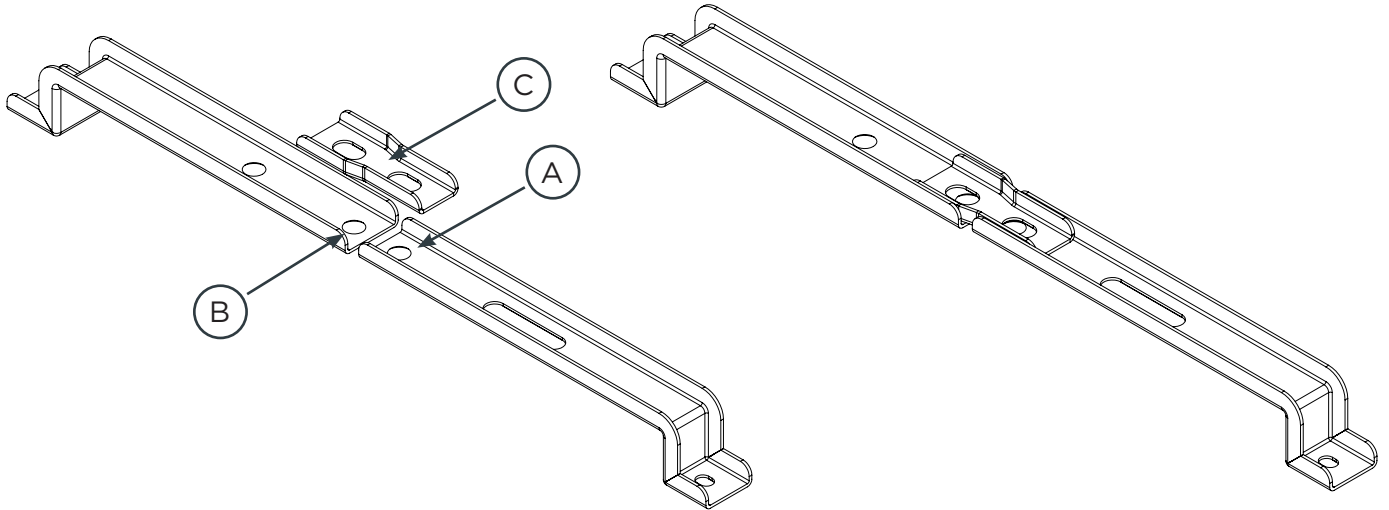

### Step 2: Assemble the two metal brackets together

Use the Allen wrench tool to hold the bolts from spinning while tightening the nuts with the 10mm wrench. Tighten the nuts to a recommended torque of  $8.5 \pm 0.5$  Nm. Note that the slots on Metal Bracket C are adjustable to align the bracket to fit the width of the two batteries tight.

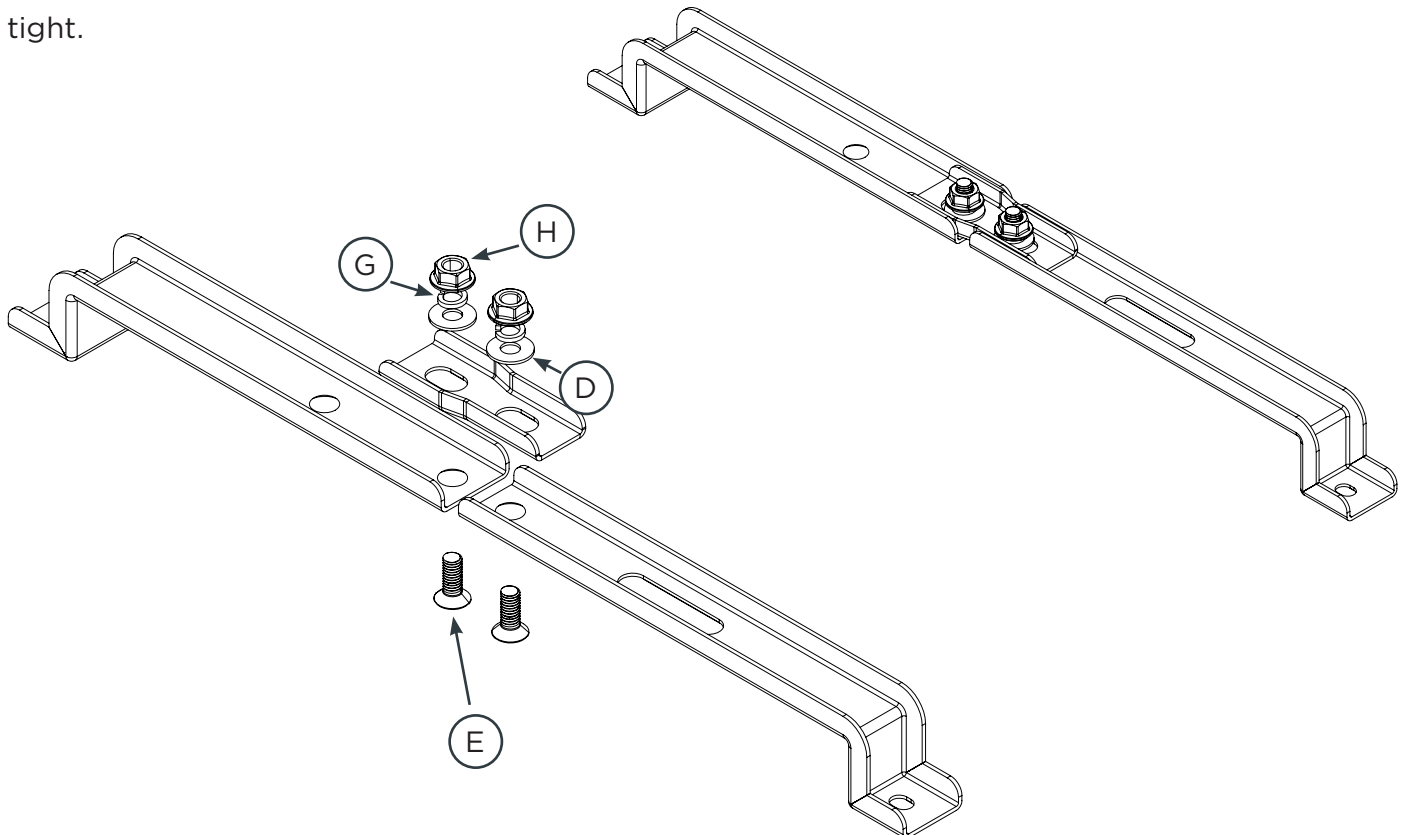

**Step 3: Drill holes for J-hook battery hold down bolts**

Drill 10mm diameter holes in the battery tray 36.6 cm apart from each other. It is recommended to align the bracket such that it does not cover the terminals, communication ports, LEDs, or push button on the battery.

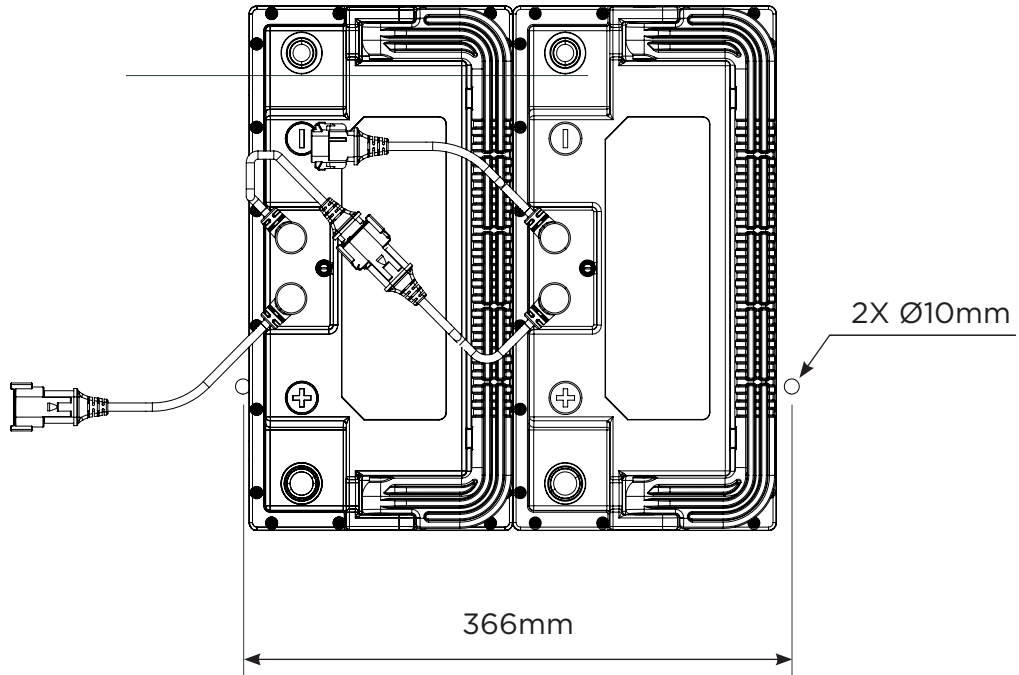

**Step 4: Feed battery hold-down bolt through right-side hole**

Angle the J-hook end of the Battery Hold-Down Bolt (J) and feed it through the right-side hole. Rotate the bolt so that it is vertical. Do not let go of the bolt as the bolt will drop below the vehicle.

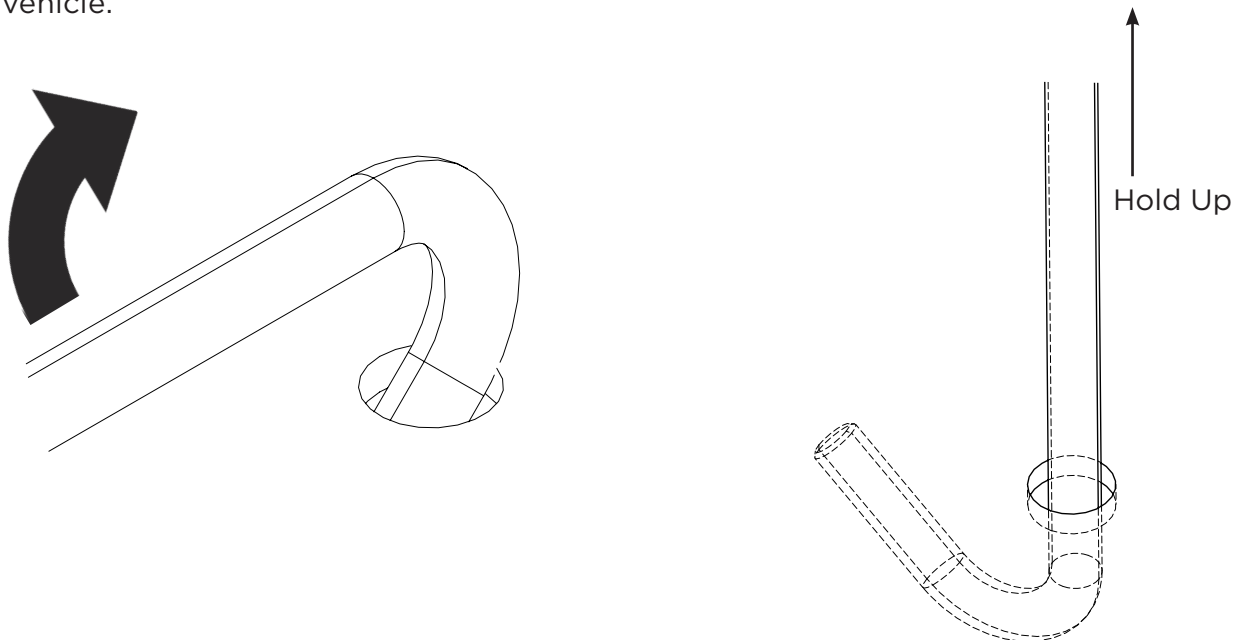

**Step 5: Loosly apply washers and nut to right-side Battery Hold-Down Bolt (J)**

Place the bracket aligned with the holes and feed the Battery Hold-Down Bolt through the right-side hole on the assembled bracket. Apply the Washer (D), then the Split Lock Washer (G), then the Anti-Loosening Nut (H) to the Battery Hold-Down Bolt (J) to loosely hold the right-side Battery Hold-Down Bolt in place.

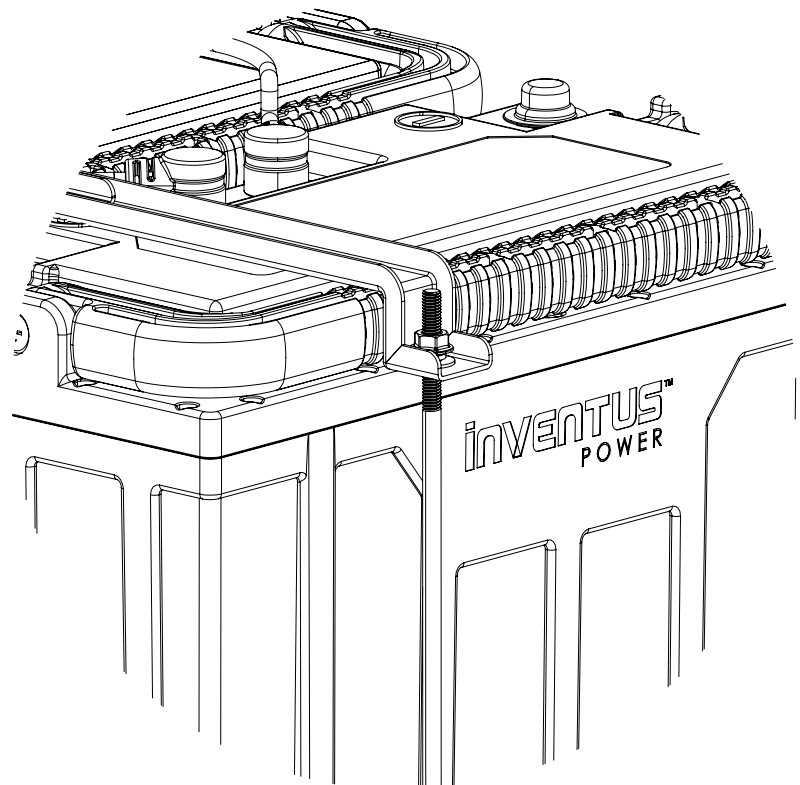
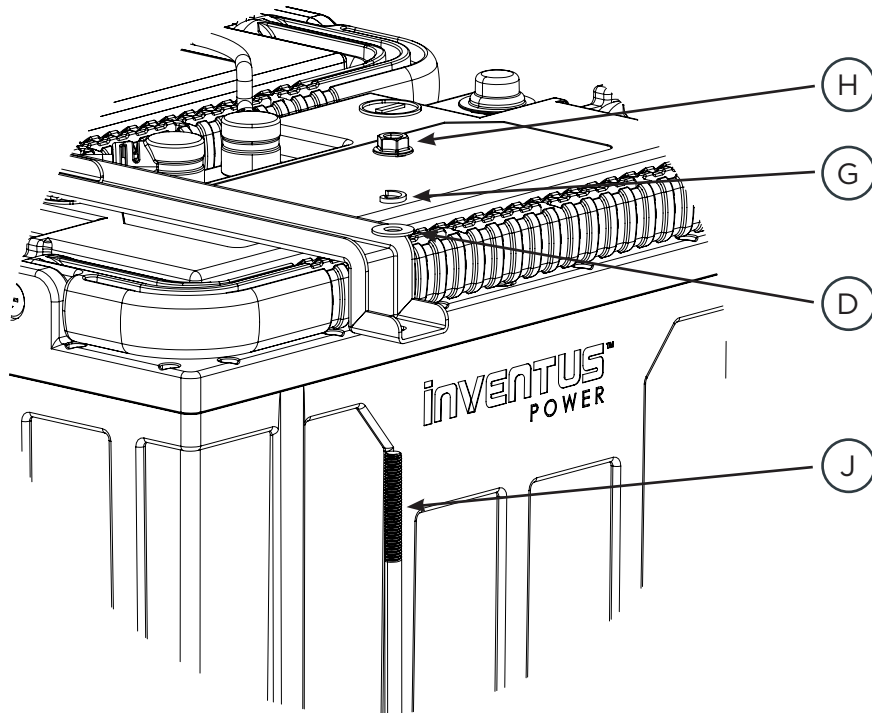

**Step 6: Repeat steps 4 and 5 on the left side to place the left-side Battery Hold-Down Bolt (J)**

**Step 7: Tighten both Anti-Loosening Nuts (H) to a recommended torque of  $8.5 \pm 0.5$  Nm**

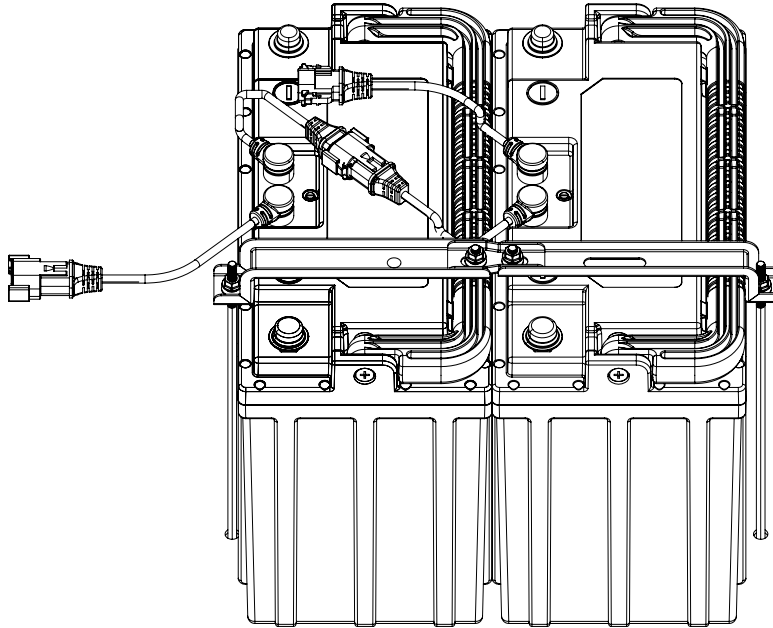

**Step 8: Apply Rubber Caps (F) to the top of each Battery Hold-Down Bolt (J)**

